



## OP-MQ+A13M1SD-10

### 40Gb/s QSFP+PSM4 Transceiver

#### Product Features

- ✓ MTP/MPO optical connector
- ✓ 4 independent full-duplex channels up  
To 11.3Gbps data rate per wavelength
- ✓ Hot-pluggable QSFP +footprint
- ✓ RoHS compliant and Lead Free
- ✓ Up to 10Km link length
- ✓ Power dissipation <3.5W (0~70°C)
- ✓ Commercial operating temperature optional
- ✓ Compliant with IEEE802.3ba, SFF-8436



#### Applications

- ✓ 40G Ethernet
- ✓ Infiniband4X SDR DDR QDR
- ✓ 40G Telecom connections

#### Product Selection

Part Number	Operating Case temperature	DDMI
OP-MQ+A13M1SD-10	Commercial(0~70°C)	Yes

#### Regulatory Compliance

- ESD to the Electrical PINs: compatible with MIL-STD-883 Method 3015
- Immunity compatible with IEC 61000-4-3
- EMI compatible with FCC Part 15 Class B EN55022 Class B (CISPR 22B) VCCI Class B
- Laser Eye Safety compatible with FDA 21CFR 1040.10 and 1040.11 EN60950, EN (IEC) 60825-1,2
- RoHscompliant with 2002/95/EC 4.1&4.2 2005/747/EC

## ■ Pin Descriptions

Pin	Symbol	Name/Description	Ref.
1	GND	Ground	
2	Tx2n	Transmitter Inverted Data Input, CML-I	
3	Tx2p	Transmitter Non-Inverted Data output, CML-I	
4	GND	Ground	
5	Tx4n	Transmitter Inverted Data Input, CML-I	
6	Tx4p	Transmitter Non-Inverted Data output, CML-I	
7	GND	GND	
8	ModSelL	The ModSelL is an input pin. When held low by the host, the module responds to 2-wire serial communication commands. The ModSelL allows the use of multiple QSFP+ modules on a single 2-wire interface bus. When the ModSelL is "High", the module shall not respond to or acknowledge any 2-wire interface communication from the host. ModSelL signal input node must be biased to the "High" state in the module	
9	ResetL	The ResetL pin must be pulled to Vcc in the QSFP+ module. A low level on the ResetL pin for longer than the minimum pulse length ( $t_{Reset\_init}$ ) initiates a complete module reset, returning all user module settings to their default state. Module Reset AssertTime ( $t_{init}$ ) starts on the rising edge after the low level on the ResetL pin is released.	
10	VccRx	+ 3.3V Power Supply Receiver	
11	SCL	2-Wire Serial Interface Clock	
12	SDA	2-Wire Serial Interface Data	
13	GND	GND	
14	Rx3p	Receiver Non-Inverted Data Output, CML-O	
15	Rx3n	Receiver Inverted Data Output, CML-O	
16	GND	GND	
17	Rx1p	Receiver Non-Inverted Data Output, CML-O	
18	Rx1n	Receiver Inverted Data Output, CML-O	
19	GND	Ground	
20	GND	Ground	
21	Rx2n	Receiver Inverted Data Output, CML-O	

22	Rx2p	Receiver Non-Inverted Data Output, CML-O	
23	GND	Ground	
24	Rx4n	Receiver Inverted Data Output, CML-O	
25	Rx4p	Receiver Non-Inverted Data Output, CML-O	
26	GND	Ground	
27	ModPrsL	Module Present, connect to GND	
28	IntL	The IntL pin is an open collector output and must be pulled to host supply voltage on the host board. The INTL pin is de-asserted "High" after completion of reset, when byte 2 bit 0 (Data Not Ready) is read with a value of '0' and the flag field is read.	
29	VccTx	+3.3 V Power Supply transmitter	
30	Vcc1	+3.3 V Power Supply	
31	LPMODE	The LPMODE pin shall be pulled up to Vcc in the QSFP+ module. This function is affected by the LPMODE pin and the combination of the Power_override and Power_set software control bits (Address A0h, byte 93 bits 0,1).	
32	GND	Ground	
33	Tx3p	Transmitter Non-Inverted Data Input, CML-I	
34	Tx3n	Transmitter Inverted Data Output, CML-I	
35	GND	Ground	
36	Tx1p	Transmitter Non-Inverted Data Input, CML-I	
37	Tx1n	Transmitter Inverted Data Output, CML-I	
38	GND	Ground	

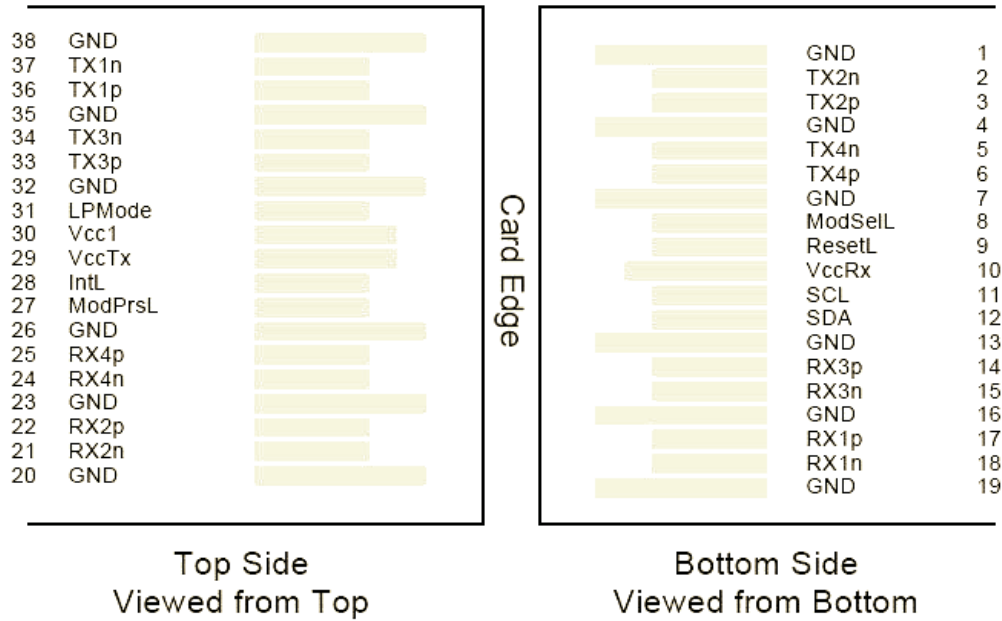

### Pin-out of Connector Block on Host Board

### Recommend Circuit Schematic

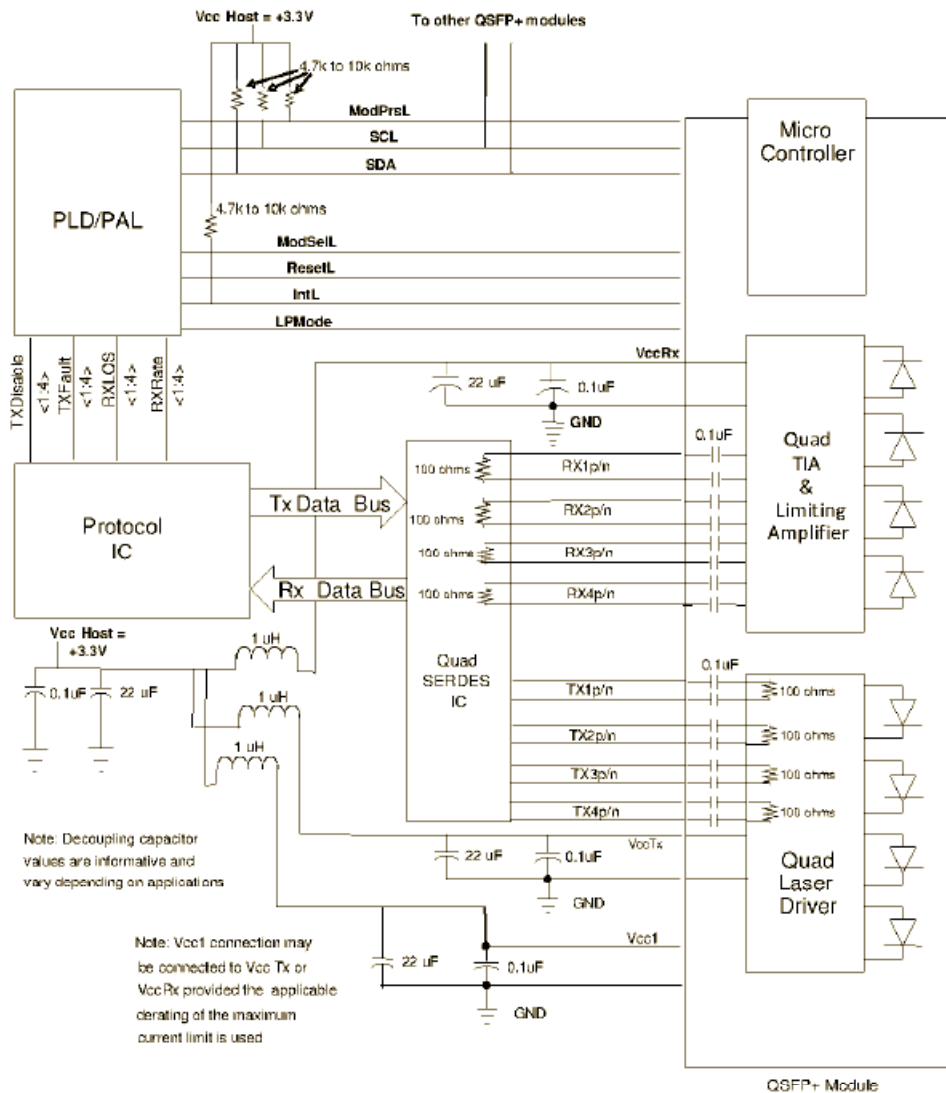

## Absolute Maximum Ratings

Parameter	Symbol	Min	Typ	Max	Unit	Ref.
Maximum Supply Voltage	Vcc	-0.5		+4.0	V	
Storage Temperature	TS	-40		+85	°C	
Operating Humidity	RH	0		85	%	

## Recommended Operating Conditions

Parameter	Symbol	Min	Typ	Max	Unit	Ref.
Power Supply Voltage	Vcc	3.13	3.30	3.47	V	
Power Supply Current	Icc	-	-	1	A	Commercial
Case Operating Temperature	Tc	0	-	+70	°C	Commercial
Bit Rate Each Lane	Br	1	-	11.3	Gbps	
9/125um G.652 SMF	Lmax	-	-	10	km	

## Electrical Characteristics (TOP=25°C, Vcc=3.3Volts)

Parameter	Symbol	Min	Typ	Max	Unit	Ref.
<b>Transmitter</b>						
Input differential impedance	Rin	80	100	120	Ω	1
Differential data input swing	Vin, pp	120	-	850	mV	
TX Disable-High	-	Vcc - 0.8	-	Vcc	V	
TX Disable-Low	-	Vee	-	Vee + 0.8	V	
TX Fault-High	-	Vcc - 0.8	-	Vcc	V	
TX Fault-Low	-	Vee	-	Vee + 0.8	V	
<b>Receiver</b>						
Single ended data output swing	Vout, pp	300	-	850	mV	2
Data output rise time	Tr	30	-	-	ps	3
Data output fall time	Tf	30	-	-	ps	3
LOS-High	-	Vcc - 0.8		Vcc	V	
LOS-Low	-	Vee		Vee + 0.8	V	

**Notes:**

1. AC coupled.
2. Into 100 ohm differential termination.
3. 20 – 80 %

**■ Optical Characteristics (TOP=25°C, Vcc=3.3 Volts)**

Parameter	Symbol	Min	Typ	Max	Unit	Ref.
<b>Transmitter</b>						
Optical Wavelength	$\lambda_c$	1260	1310	1355	nm	
Side-mode Suppression Ratio	SMSR	30			dB	
Total Average Launch Power	PT			8.3	dBm	
Average Launch Power, each Lane		-7		2.3	dBm	
Optical Modulation Amplitude, each Lane	OMA	-4		+3.5	dBm	
Extinction Ratio	ER	3.5			dB	
TDP, each Lane	TDP			2.3	dB	
Relative Intensity Noise	RIN			-128	dB/Hz	
Transmitter Reflectance	RT			-12	dB	
<b>Receiver</b>						
RX Sensitivity @10.3 Gb/s, each lane	SENS	-	-	-11.5	dBm	1,2
Receiver Overload		2.3	-	-	dBm	
Difference in Receive Power between any two Lanes (OMA)				7.5	dB	
LOS De-Assert	LOSD	-	-	-12	dBm	
LOS Assert	LOSA	-25	-	-	dBm	
LOS Hysteresis	-	0.5	-	-	dB	

**Notes:**

1. Measured with conformance signals defined in FC-P1-2 Rev. 10.0 specifications.
2. Measured with PRBS 231-1 at 10-12 BER.

### ■ Mechanical Specifications

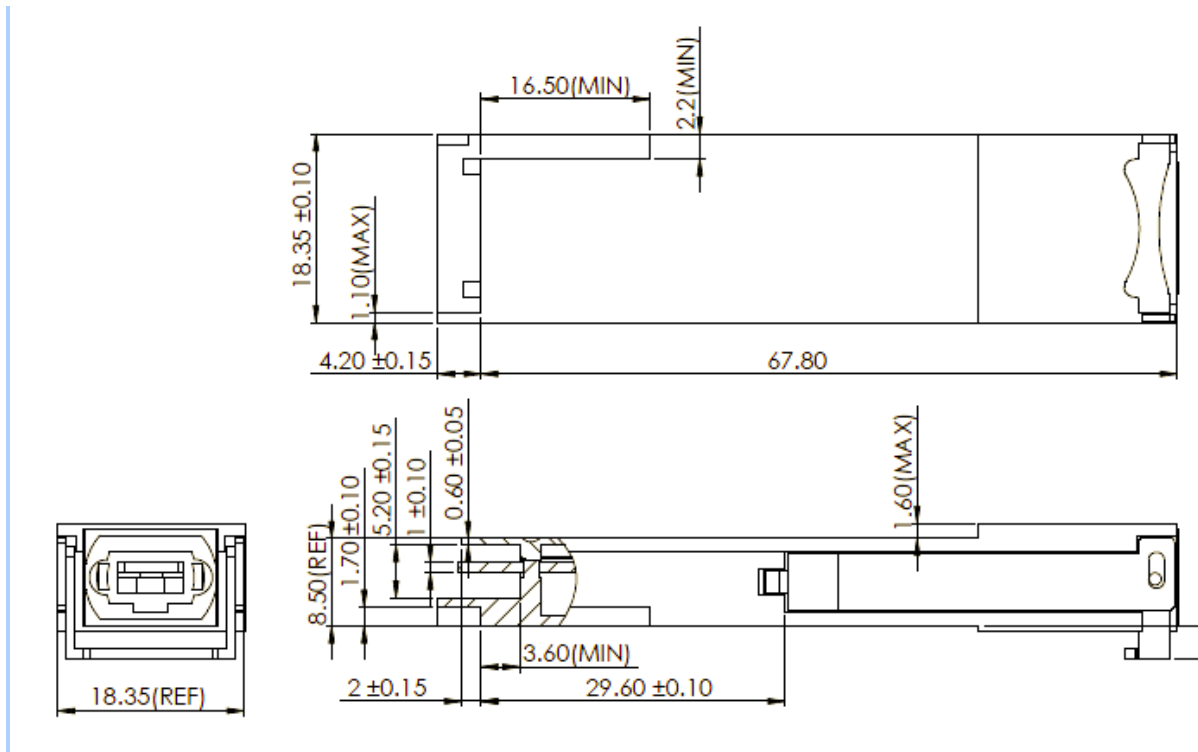

### ■ Optical Interface Lanes and Assignment

shows the orientation of the multi-mode fiber facets of the optical connector. Table 1 provides the lane assignment.

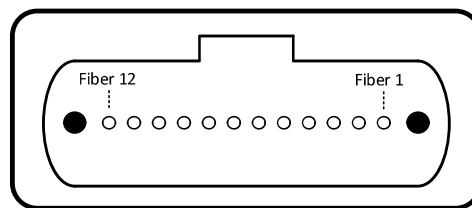

Outside view of the QSFP module MPO

### ■ EEPROM Information

EEPROM memory map specific data field description is as below:

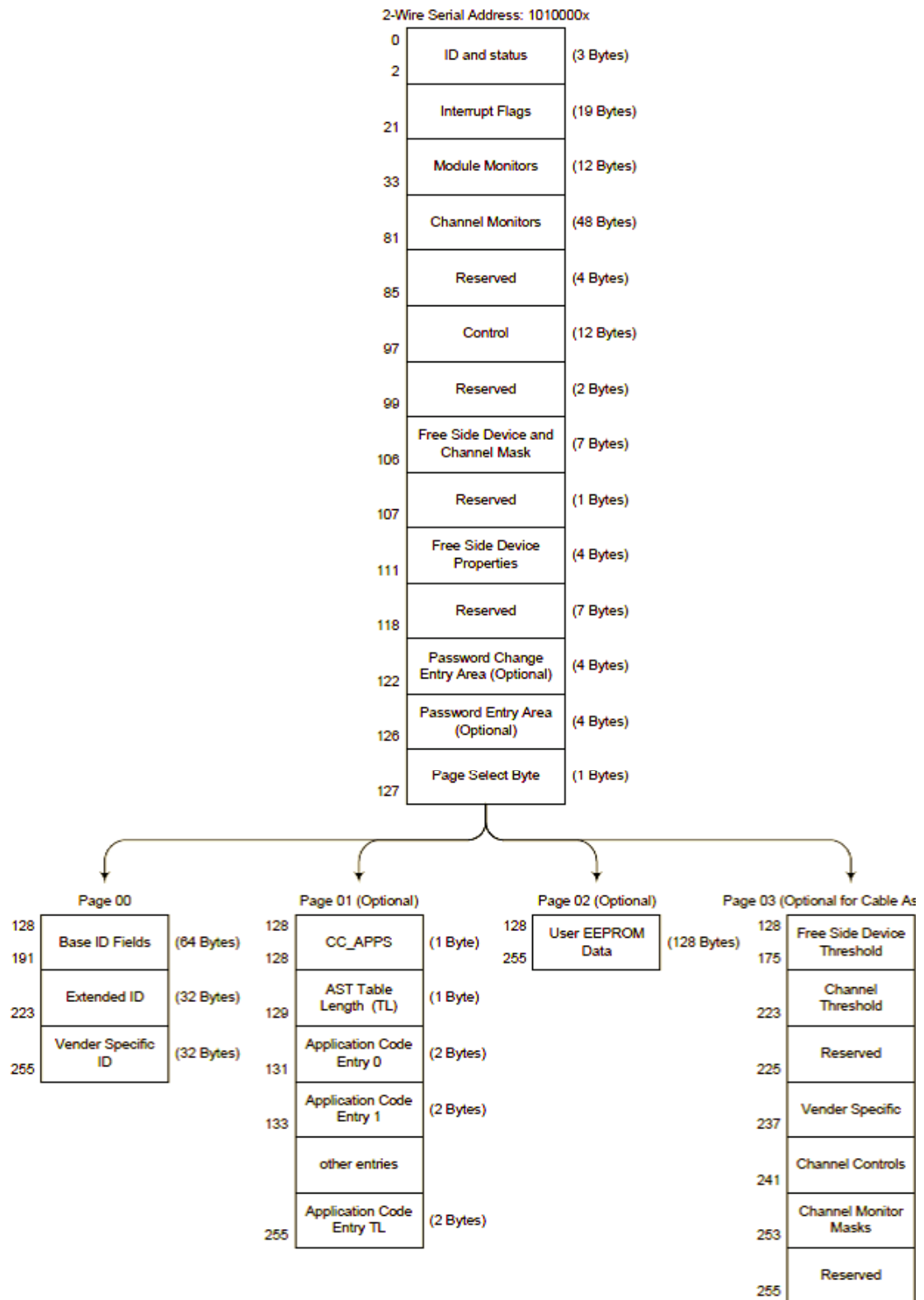



## ■ Digital Diagnostic Monitoring Interface

Four transceiver parameter values are monitored. The following table defines the Monitoring parameter's accuracy.

Parameter	Range	Accuracy	Calibration
Temperature	0 to +70°C	±3°C	Internal
Voltage	2.97 to 3.63V	±3%	Internal
Bias Current	0 to 100mA	±10%	Internal
RX Power	-12 to 2.5dBm	±3dB	Internal

## ■ For More Information

Shenzhen Optostar Optoelectronics Co., Ltd  
Address: A-14, Haide Building, Haide Second Road Nanshan District, Shenzhen, P.R. China  
Tel: +86-755-26400198 +86-755-26400288  
Fax: +86-755-26411001  
Email: info@optostar.com.cn  
Skype: ouyangroya  
Web: www.optostar.com.cn